

DRIVER: Nathan Dean  
 EVENT: Weekly, Open Tire  
 CLASS: Mod Sprint  
 TRACK: Comp R/C OKC, OK

Clay  Hard Packed  Loose Dirt  
 Carpet  Asphalt  Concrete  
 Flat  Banked  True Oval  Tri-Oval  
 Traction:  High  Medium  Low

<b>LEFT</b>	<b>FRONT SUSPENSION</b>	<b>RIGHT</b>
CAMBER <u>0</u> <u>0</u>		
CASTOR		
<input type="checkbox"/> +10° <input checked="" type="checkbox"/> +5° <input type="checkbox"/> 0° <input type="checkbox"/> -5° <input type="checkbox"/> -10° <input checked="" type="checkbox"/> +10° <input type="checkbox"/> +5° <input type="checkbox"/> 0° <input type="checkbox"/> -5° <input type="checkbox"/> -10°		
ACKERMANN		
<input type="checkbox"/> OUTER <input type="checkbox"/> MIDDLE <input checked="" type="checkbox"/> INNER <input checked="" type="checkbox"/> INNER <input type="checkbox"/> MIDDLE <input type="checkbox"/> OUTER		
Full/.125" AXLE SHIMS Full/.125"		
OUTER CAMBER LINK LOCATION		
<input checked="" type="checkbox"/> OUTER <input type="checkbox"/> INNER <input type="checkbox"/> INNER <input checked="" type="checkbox"/> OUTER		
<input checked="" type="checkbox"/> 0° <input type="checkbox"/> ANGLED KINGPIN INCLINE <input type="checkbox"/> ANGLED <input checked="" type="checkbox"/> 0°		
.125" CAMBER RATE SHIMS .125"		
SUSPENSION LOCATION		
<input checked="" type="checkbox"/> OUTER <input type="checkbox"/> MIDDLE <input type="checkbox"/> INNER <input type="checkbox"/> INNER <input type="checkbox"/> MIDDLE <input checked="" type="checkbox"/> OUTER		
KICK-UP: <input type="checkbox"/> 15° LO <input type="checkbox"/> 15° HIGH <input type="checkbox"/> 20° LO <input type="checkbox"/> 20° HIGH <input type="checkbox"/> 25° <input checked="" type="checkbox"/> 35°		
TOE: <u>OUT</u> SWAY BAR: <input checked="" type="checkbox"/> NONE <input type="checkbox"/>		

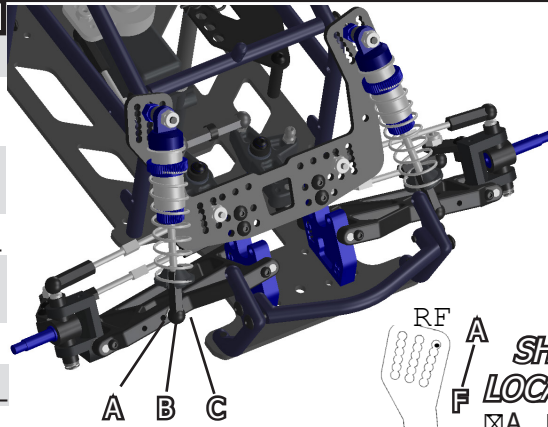

**SHOCK LOCATION:**  
 ON SUSP ARM:  
 A  B  C

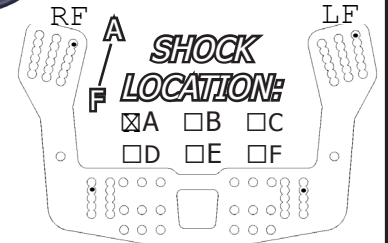

-SHADE IN MOUNTING LOCATIONS ON SUSPENSION ARMS, BEARING CARRIER AND SHOCK TOWER.

<b>TIRES &amp; TRACTION</b>		
TIRE TYPE: <input type="checkbox"/> FOAM <input type="checkbox"/> STREET RUBBER <input type="checkbox"/> LOOSE		
COMPOUND	DIAMETER	INSERT
RF: <u>Ribs</u>		<u>Stock</u>
LF: <u>Ribs</u>		<u>"</u>
RR: <u>HB Gigabyte Pink</u>		<u>"</u>
LR: <u>HB Gigabyte Pink</u>		<u>"</u>
CLEANED WITH: <u>Water</u>		
TRACTION ADDITIVE: <u>PB Blaster</u>		
NOTES:		

<b>SHOCKS</b>			
COLLAR LENGTH		SHOCK LENGTH	
<b>LEFT FRONT</b>	<b>BODY LENGTH</b>	<b>RIGHT FRONT</b>	<b>BODY LENGTH</b>
<input type="checkbox"/> SHORT <input type="checkbox"/> MED <input checked="" type="checkbox"/> LONG		<input type="checkbox"/> SHORT <input type="checkbox"/> MED <input checked="" type="checkbox"/> LONG	
<b>SHAFT LENGTH</b>		<b>SHAFT LENGTH</b>	
<input type="checkbox"/> SHORT <input type="checkbox"/> MED <input checked="" type="checkbox"/> LONG		<input type="checkbox"/> SHORT <input type="checkbox"/> MED <input checked="" type="checkbox"/> LONG	
SPRING: <u>CW Blue</u>		SPRING: <u>CW Blue</u>	
OIL: <u>25 Assoc</u>		OIL: <u>25 Assoc</u>	
PISTON: <u>M</u>		PISTON: <u>M</u>	
LENGTH: _____		LENGTH: _____	
COLLAR: <u>.39</u>		COLLAR: <u>.31</u>	
<b>LEFT REAR</b>	<b>BODY LENGTH</b>	<b>RIGHT REAR</b>	<b>BODY LENGTH</b>
<input type="checkbox"/> SHORT <input type="checkbox"/> MED <input checked="" type="checkbox"/> LONG		<input type="checkbox"/> SHORT <input type="checkbox"/> MED <input checked="" type="checkbox"/> LONG	
<b>SHAFT LENGTH</b>		<b>SHAFT LENGTH</b>	
<input type="checkbox"/> SHORT <input type="checkbox"/> MED <input checked="" type="checkbox"/> LONG		<input type="checkbox"/> SHORT <input type="checkbox"/> MED <input checked="" type="checkbox"/> LONG	
SPRING: <u>CW White</u>		SPRING: <u>CW White</u>	
OIL: <u>30 Assoc</u>		OIL: <u>30 Assoc</u>	
PISTON: <u>M</u>		PISTON: <u>M</u>	
LENGTH: _____		LENGTH: _____	
COLLAR: <u>.33</u>		COLLAR: <u>.41</u>	

<b>LEFT</b>	<b>REAR SUSPENSION</b>	<b>RIGHT</b>
CAMBER <u>+1.5</u> <u>-1.5</u>		
TOE <u>-6</u> <u>+2</u>		
WHEEL SPACERS		
<input type="checkbox"/> .250" <input type="checkbox"/> .125" <input checked="" type="checkbox"/> NONE <input type="checkbox"/> NONE <input checked="" type="checkbox"/> .125" <input type="checkbox"/> .250"		
BEARING CARRIER SPACING		
RIGHT: <input type="checkbox"/> FWD <input type="checkbox"/> 1-OFF FWD <input checked="" type="checkbox"/> MIDDLE <input type="checkbox"/> 1-OFF REAR <input type="checkbox"/> REAR LEFT: <input type="checkbox"/> FWD <input type="checkbox"/> 1-OFF FWD <input checked="" type="checkbox"/> MIDDLE <input type="checkbox"/> 1-OFF REAR <input type="checkbox"/> REAR		
<input type="checkbox"/> LONG <input checked="" type="checkbox"/> SHORT INNER SUSP MOUNT <input type="checkbox"/> SHORT <input checked="" type="checkbox"/> LONG		
ANTI-SQUAT SHIMS		
<input type="checkbox"/> 3° <input checked="" type="checkbox"/> 1.5° <input type="checkbox"/> NONE <input type="checkbox"/> NONE <input checked="" type="checkbox"/> 1.5° <input type="checkbox"/> 3°		
ROLL CENTER SHIMS		
<input type="checkbox"/> .125" <input type="checkbox"/> .060" <input checked="" type="checkbox"/> NONE <input checked="" type="checkbox"/> NONE <input type="checkbox"/> .060" <input type="checkbox"/> .125"		
OUTER CAMBER LINK LOCATION		
<input checked="" type="checkbox"/> OUTER <input type="checkbox"/> INNER <input type="checkbox"/> INNER <input checked="" type="checkbox"/> OUTER		
BEARING CARRIER PIN HEIGHT		
<input type="checkbox"/> HIGH R.C. <input checked="" type="checkbox"/> LOW R.C. (NEAR AXLE) <input checked="" type="checkbox"/> LOW R.C. <input type="checkbox"/> HIGH R.C.		

SHOCK LOCATION:  A  B  C  D  E

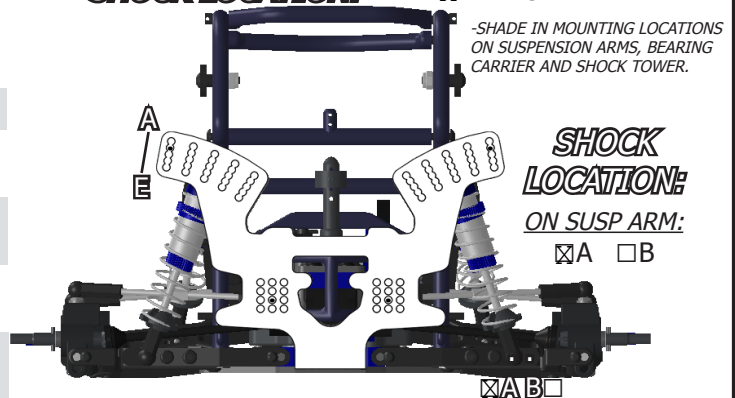

-SHADE IN MOUNTING LOCATIONS ON SUSPENSION ARMS, BEARING CARRIER AND SHOCK TOWER.

**SHOCK LOCATION:**  
 ON SUSP ARM:  
 A  B



**RECEIVER**  
 AS SHOWN

**SPEED CONTROL**  
 AS SHOWN  
 By Receiver

**TRANNY LOCATION**  
 FORWARD  
 REAR

**ADDED WEIGHT**  
 FRONT \_\_\_\_\_  
 MIDDLE \_\_\_\_\_  
 REAR \_\_\_\_\_

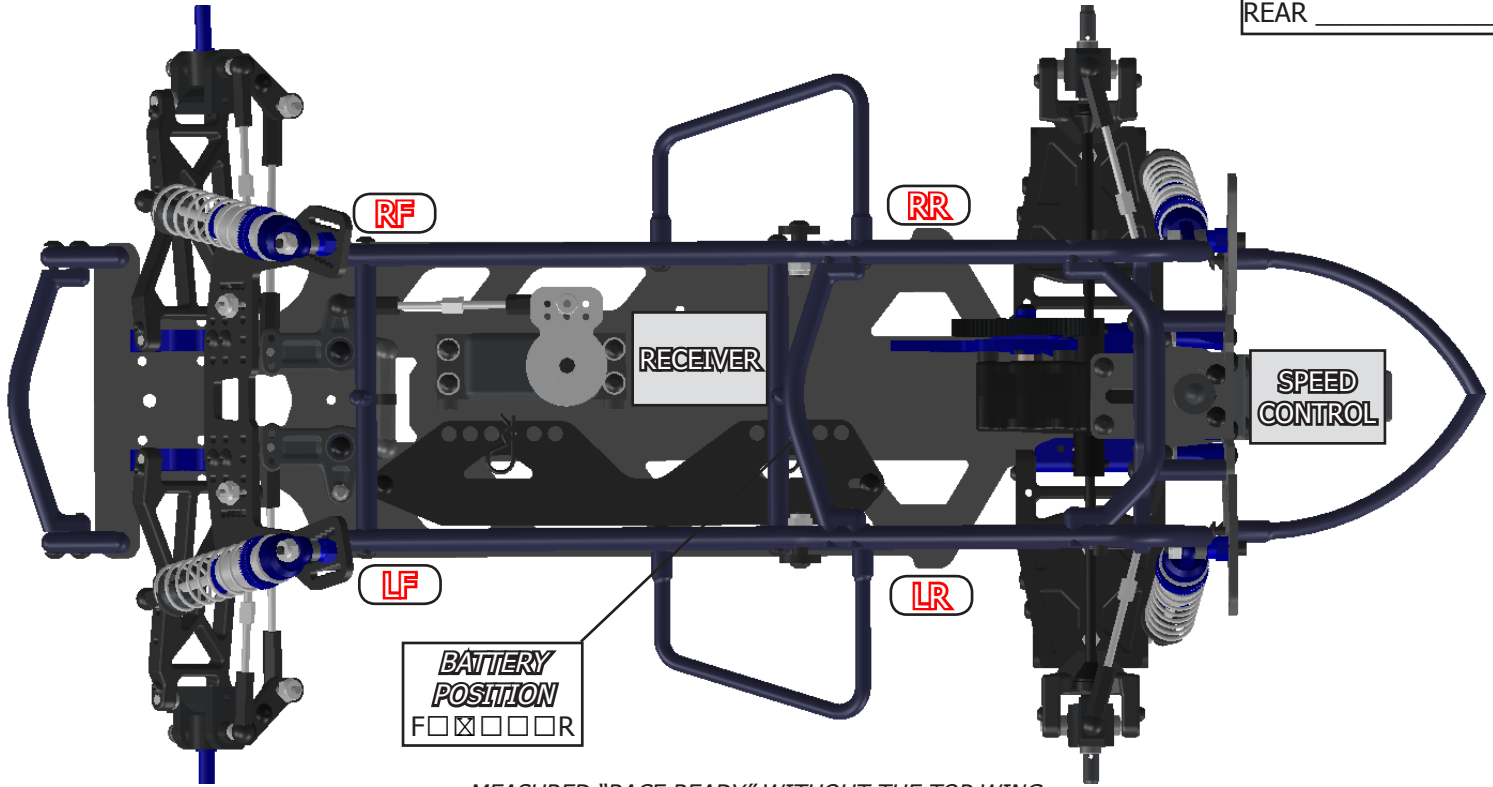

-MEASURED "RACE READY" WITHOUT THE TOP WING

<p><b>RIDE HEIGHTS BY LOCATION:</b></p> <p>LF: <u>  .71  </u> RF: <u>  .75  </u></p> <p>LR: <u>  .69  </u> RR: <u>  .72  </u></p> <p><b>MEASURED FROM:</b>  <input checked="" type="checkbox"/> TOP OF CHASSIS   <input type="checkbox"/> BOTTOM OF CHASSIS</p>	<p><b>CORNER WEIGHTS:</b></p> <p>LF: <u> 13.8 </u> RF: <u> 10.2 </u></p> <p>LR: <u> 16.9 </u> RR: <u> 18.7 </u></p> <p><b>OVERALL:</b> _____</p>	<p><b>MAX CHASSIS HEIGHT:</b></p> <p>LF: _____ RF: _____</p> <p>LR: _____ RR: _____</p> <p><b>MEASURED FROM:</b>  <input type="checkbox"/> TOP OF CHASSIS   <input type="checkbox"/> BOTTOM OF CHASSIS</p>
<p><b>POWER SETTINGS</b></p> <p>MOTOR: <u>  8.5  </u></p> <p>AMP DRAW: _____</p> <p>TIMING: _____</p> <p>PINION: <u>  24  </u></p> <p>SPUR: <u>  84  </u></p> <p>SPEED CONTROL: _____  <input type="checkbox"/> "BLINKY"   <input type="checkbox"/> OPEN</p> <p>SETTINGS: _____</p>	<p><b>AERO</b></p> <p><b>MAIN WING</b>  <input type="checkbox"/> 6X6  <input checked="" type="checkbox"/> 7X7</p> <p><b>FRONT WING</b>  <input type="checkbox"/> NONE   <input type="checkbox"/> SMALL  <input checked="" type="checkbox"/> LARGE</p> <p><b>HOOD TYPE</b>  <input type="checkbox"/> TRADITIONAL  <input checked="" type="checkbox"/> SCOOP (HIGH DF)</p>	<p><b>MAIN WING LOCATION</b></p>
<p>BATTERY: _____</p> <p>MOTOR TEMP AFTER RUN: _____</p>		

**NOTES:** Front wheelbase short using shims on outer hinge pin.